

Installation Note

Extended Frequency Range Upgrade Kit (50 GHz to 67 GHz)

Upgrade Kit Number: E8364-60105

For E8364B Microwave Network Analyzers WITHOUT the Configurable Test Set Option (Option 014)



Agilent Technologies

Agilent Part Number: E8364-90022

Printed in USA August 2004

Supersedes Print Date: July 2004

© Agilent Technologies, Inc. 2003, 2004

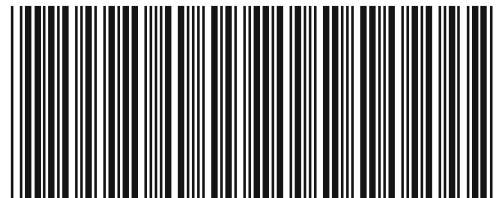

E8364-90022

WARRANTY STATEMENT

THE MATERIAL CONTAINED IN THIS DOCUMENT IS PROVIDED “AS IS,” AND IS SUBJECT TO BEING CHANGED, WITHOUT NOTICE, IN FUTURE EDITIONS. FURTHER, TO THE MAXIMUM EXTENT PERMITTED BY APPLICABLE LAW, AGILENT DISCLAIMS ALL WARRANTIES, EITHER EXPRESS OR IMPLIED WITH REGARD TO THIS MANUAL AND ANY INFORMATION CONTAINED HEREIN, INCLUDING BUT NOT LIMITED TO THE IMPLIED WARRANTIES OF MERCHANTABILITY AND FITNESS FOR A PARTICULAR PURPOSE. AGILENT SHALL NOT BE LIABLE FOR ERRORS OR FOR INCIDENTAL OR CONSEQUENTIAL DAMAGES IN CONNECTION WITH THE FURNISHING, USE, OR PERFORMANCE OF THIS DOCUMENT OR ANY INFORMATION CONTAINED HEREIN. SHOULD AGILENT AND THE USER HAVE A SEPARATE WRITTEN AGREEMENT WITH WARRANTY TERMS COVERING THE MATERIAL IN THIS DOCUMENT THAT CONFLICT WITH THESE TERMS, THE WARRANTY TERMS IN THE SEPARATE AGREEMENT WILL CONTROL.

DFARS/Restricted Rights Notice

If software is for use in the performance of a U.S. Government prime contract or subcontract, Software is delivered and licensed as “Commercial computer software” as defined in DFAR 252.227-7014 (June 1995), or as a “commercial item” as defined in FAR 2.101(a) or as “Restricted computer software” as defined in FAR 52.227-19 (June 1987) or any equivalent agency regulation or contract clause. Use, duplication or disclosure of Software is subject to Agilent Technologies’ standard commercial license terms, and non-DOD Departments and Agencies of the U.S. Government will receive no greater than Restricted Rights as defined in FAR 52.227-19(c)(1-2) (June 1987). U.S. Government users will receive no greater than Limited Rights as defined in FAR 52.227-14 (June 1987) or DFAR 252.227-7015 (b)(2) (November 1995), as applicable in any technical data.

Safety Notes

The following safety notes are used throughout this document. Familiarize yourself with each of these notes and its meaning before performing any of the procedures in this document.

WARNING	Warning denotes a hazard. It calls attention to a procedure which, if not correctly performed or adhered to, could result in injury or loss of life. Do not proceed beyond a warning note until the indicated conditions are fully understood and met.
----------------	---------------------------------------------------------------------------------------------------------------------------------------------------------------------------------------------------------------------------------------------------------------

CAUTION	Caution denotes a hazard. It calls attention to a procedure that, if not correctly performed or adhered to, could result in damage to or destruction of the instrument. Do not proceed beyond a caution sign until the indicated conditions are fully understood and met.
----------------	---------------------------------------------------------------------------------------------------------------------------------------------------------------------------------------------------------------------------------------------------------------------------

Getting Assistance from Agilent

By internet, phone, or fax, get assistance with all your test and measurement needs.

Online assistance: www.agilent.com/find/assist			
Americas			
Brazil (tel) (+55) 11 3351 7012 (fax) (+55) 11 3351 7024	Canada (tel) 888 447 7378 (fax) 905 282 6495	Mexico (tel) 1 800 254 2440 (fax) 1 800 254 4222	United States (tel) 800 829 4444 (alt) (+1) 303 662 3998 (fax) 800 829 4433
Asia Pacific and Japan			
Australia (tel) 1 800 225 574 (fax) 1 800 681 776 (fax) 1 800 225 539	China (tel) 800 810 0508 (alt) 800 810 0510 (fax) 800 810 0507 (fax) 800 810 0362	Hong Kong (tel) 800 933 229 (fax) 800 900 701	India (tel) 1600 112 626 (fax) 1600 112 727 (fax) 1600 113 040
Japan (Bench) (tel) 0120 32 0119 (alt) (+81) 426 56 7799 (fax) 0120 01 2144	Japan (On-Site) (tel) 0120 802 363 (alt) (+81) 426 56 7498 (fax) (+81) 426 60 8953	Singapore (tel) 1 800 275 0880 (fax) (+65) 6755 1235 (fax) (+65) 6755 1214	South Korea (tel) 080 778 0011 (fax) 080 778 0013
Taiwan (tel) 0800 047 669 (fax) 0800 047 667 (fax) 886 3492 0779	Thailand (tel) 1 800 2758 5822 (alt) (+66) 2267 5913 (fax) 1 800 656 336	Malaysia (tel) 1800 880 399 (fax) 1800 801 054	
Europe			
Austria (tel) 0820 87 44 11* (fax) 0820 87 44 22	Belgium (tel) (+32) (0)2 404 9340 (alt) (+32) (0)2 404 9000 (fax) (+32) (0)2 404 9395	Denmark (tel) (+45) 7013 1515 (alt) (+45) 7013 7313 (fax) (+45) 7013 1555	Finland (tel) (+358) 10 855 2100 (fax) (+358) (0) 10 855 2923
France (tel) 0825 010 700* (alt) (+33) (0)1 6453 5623 (fax) 0825 010 701*	Germany (tel) 01805 24 6333* (alt) 01805 24 6330* (fax) 01805 24 6336*	Ireland (tel) (+353) (0)1 890 924 204 (alt) (+353) (0)1 890 924 206 (fax) (+353) (0)1 890 924 024	Israel (tel) (+972) 3 9288 500 (fax) (+972) 3 9288 501
Italy (tel) (+39) (0)2 9260 8484 (fax) (+39) (0)2 9544 1175	Luxemburg (tel) (+32) (0)2 404 9340 (alt) (+32) (0)2 404 9000 (fax) (+32) (0)2 404 9395	Netherlands (tel) (+31) (0)20 547 2111 (alt) (+31) (0)20 547 2000 (fax) (+31) (0)20 547 2190	Russia (tel) (+7) 095 797 3963 (alt) (+7) 095 797 3900 (fax) (+7) 095 797 3901
Spain (tel) (+34) 91 631 3300 (alt) (+34) 91 631 3000 (fax) (+34) 91 631 3301	Sweden (tel) 0200 88 22 55* (alt) (+46) (0)8 5064 8686 (fax) 020 120 2266*	Switzerland (French) (tel) 0800 80 5353 opt. 2* (alt) (+33) (0)1 6453 5623 (fax) (+41) (0)22 567 5313	Switzerland (German) (tel) 0800 80 5353 opt. 1* (alt) (+49) (0)7031 464 6333 (fax) (+41) (0)1 272 7373
Switzerland (Italian) (tel) 0800 80 5353 opt. 3* (alt) (+39) (0)2 9260 8484 (fax) (+41) (0)22 567 5314	United Kingdom (tel) (+44) (0)7004 666666 (alt) (+44) (0)7004 123123 (fax) (+44) (0)7004 444555		
(tel) = primary telephone number; (alt) = alternate telephone number; (fax) = FAX number; * = in country number			
			8/03/04

About the Upgrade Kit

Products affected	E8364B with no RF hardware options
Installation to be performed by	Agilent service center or personnel qualified by Agilent
Estimated installation time	2.5 hours
Estimated adjustment time	1 hour
Estimated full instrument calibration time	4.5 hours

If you need assistance, refer to [“Getting Assistance from Agilent”](#) on page 3.

Description of the Upgrade

This upgrade kit is used to extend the frequency range of the:

- E8364B PNA microwave network analyzer from 50 GHz to 67 GHz

This upgrade applies only to a standard PNA, with no optional hardware.

Items Included in the Upgrade Kit

Check the contents of your kit against the following list. If any item is missing or damaged, contact Agilent Technologies. Refer to [“Getting Assistance from Agilent”](#) on page 3.

Table 1 Option 067 Upgrade Kit (E8364-60105) to Extend the E8364B to 67 GHz

Ref. Desig.	Description	Qty	Part Number
N/A	Installation note (this document)	1	E8364-90022
N/A	License key certificate	1	5964-5136
N/A	Model number nameplate (E8361A)	1	E8361-80001
N/A	Front panel overlay, no options	1	E8361-80002
A12	A12 source 20	1	E8361-60002
A17	LOMA 12	1	5087-7247
A18	MA 24	1	5087-7248
A22	Switch	1	5087-7238
A23	SOMA 70, port 1	2	5087-7249
A24	SOMA 70, port 2		
A25	Test port 1 coupler	2	5087-7225
A26	Test port 2 coupler		
A27	Channel A first converter (mixer)	4	5087-7258
A28	Channel R1 first converter (mixer)		
A29	Channel R2 first converter (mixer)		
A30	Channel B first converter (mixer)		
N/A	Mixer bias board	1	E8361-63044
N/A	SOMA 70 bracket	2	E8361-00002
N/A	Machine screw M3.0 x 10 (for attaching A22 switch)	2	0515-0374
N/A	Machine screw M3.0 x 6 (for attaching SOMA 70 brackets)	6	0515-0430
N/A	Machine screw M3.0 x 25 (for attaching SOMA 70s to brackets)	8	0515-0667
N/A	Ribbon cable, A23/A24 SOMA 70s to A16 test set motherboard	2	8121-1001
N/A	Cable, stranded wire, A22 switch to A16 test set motherboard	1	8121-0990

Table 1 Option 067 Upgrade Kit (E8364-60105) to Extend the E8364B to 67 GHz

Ref. Desig.	Description	Qty	Part Number
W2	A21 SOMA 50 to A22 switch	1	E8361-20002
W3	A22 switch to A23 SOMA 70	1	E8361-20003
W4	A22 switch to A24 SOMA 70	1	E8361-20004
W5	A23 SOMA 70 to A25 test port 1 coupler	1	E8361-20005
W6	A24 SOMA 70 to A26 test port 2 coupler	1	E8361-20006
W7	A23 SOMA 70 to A28 channel R1 mixer	1	E8361-20009
W8	A24 SOMA 70 to A29 channel R2 mixer	1	E8361-20010
W9	A25 test port 1 coupler to A27 channel A mixer	1	E8361-20007
W10	A26 test port 2 coupler to A30 channel B mixer	1	E8361-20008
W20	A8 fractional-N synthesizer J106 to A17 LOMA 12 J2	1	E8361-20045
W21	A8 fractional-N synthesizer J101 to A17 LOMA 12 J3	1	E836120046
W38	A23 SOMA 70 to A16 test set motherboard	1	E8361-60124
W39	A24 SOMA 70 to A16 test set motherboard	1	E8361-60123

Installation Procedure for the Upgrade Kit

The network analyzer must be in proper working condition prior to installing this option. Any necessary repairs must be made before proceeding with this installation.

WARNING **This installation requires the removal of the analyzer’s protective outer covers. The analyzer must be powered down and disconnected from the mains supply before performing this procedure.**

Electrostatic Discharge Protection

Protection against electrostatic discharge (ESD) is essential while removing or connecting cables or assemblies within the network analyzer.

Static electricity can build up on your body and can easily damage sensitive internal circuit elements when discharged. Static discharges too small to be felt can cause permanent damage. To prevent damage to the instrument:

- *always* wear a grounded wrist strap having a 1 M Ω resistor in series with it when handling components and assemblies.
- *always* use a grounded, conductive table mat while working on the instrument.
- *always* wear a heel strap when working in an area with a conductive floor. If you are uncertain about the conductivity of your floor, wear a heel strap.

Figure 1 shows a typical ESD protection setup using a grounded mat and wrist strap. Refer to “Tools Required for the Installation” on page 8 for part numbers.

Figure 1 **ESD Protection Setup**

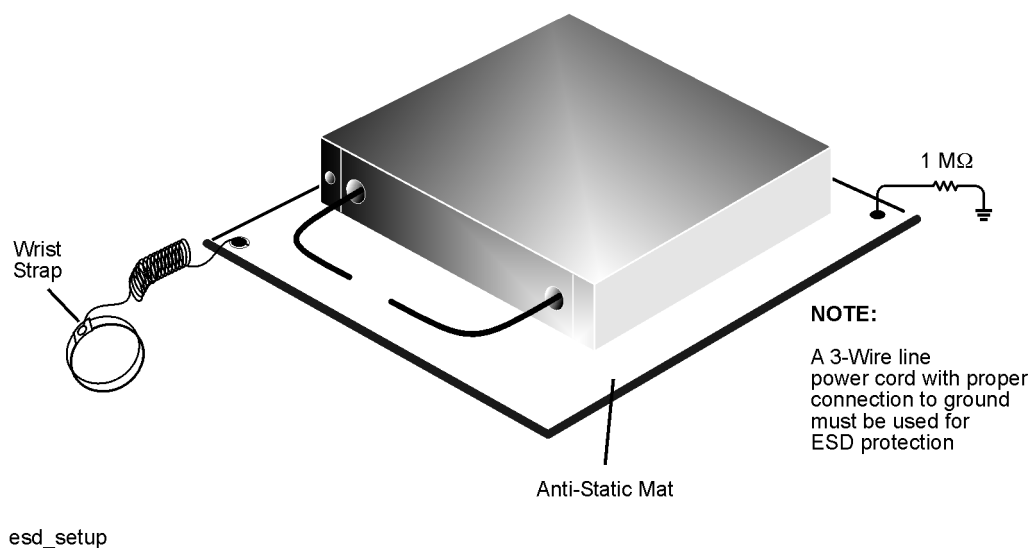

Overview of the Installation Procedure

Step 1. Verify the Model, Serial, and Option Numbers of the Analyzer

Step 2. Remove the Outer and Inner Covers

Step 3. Replace the A12 Source 20

Step 4. Replace the Top Side to Bottom Side Cables

Step 5. Raise the Receiver Deck

Step 6. Remove the Old Bottom Side Hardware and Cables

Step 7. Install the New Hardware and Cables

Step 8. Lower the Receiver Deck

Step 9. Replace the Front Panel Nameplate and Overlay

Step 10. Reinstall the Inner and Outer Covers

Step 11. Enter the New Model Number

Step 12. Perform Post-Upgrade Adjustments

Tools Required for the Installation

Description	Agilent Part Number
T-10 TORX driver (set to 9 in-lbs)	N/A
T-20 TORX driver (set to 21 in-lbs)	N/A
5/16-inch torque wrench (set to 10 in-lbs)	N/A
1-inch torque wrench (set to 72 in-lbs)	N/A

ESD Equipment and Supplies Required for the Installation

Description	Agilent Part Number
ESD grounding wrist strap	9300-1367
5-ft grounding cord for wrist strap	9300-0980
2 x 4 ft conductive table mat and 15-ft grounding wire	9300-0797
ESD heel strap (for use with conductive floors)	9300-1308

Test Equipment Required for Post-Upgrade Adjustments

Description	Agilent Part Number
Power meter	E4418B/E4419B
Power sensor, Type-N (100 kHz–4.2 GHz)	8482A
Power sensor, 2.4 mm (4.2 GHz–50 GHz)	8487A
Power sensor, V-Band (50 GHz–67 GHz) ^a	V8486A
Adapter, WR-15 to 1.85 mm (m) ^a	V281B
Adapter, 1.85 mm (f) to 1.85 mm (f) ^b	85058-60114
Adapter, 3.5 mm (m) to 2.4 mm (f)	11901D
Adapter, 2.4 mm (f) to 2.4 mm (f) ^b	11900B
Adapter, Type-N (f) to 2.4 mm (f)	11903B
Adapter, SMA (m) to SMA (f), right angle	1250-1249
Test cable, 2.4 mm (f) to 2.4 mm (f) ^b or Test cable, 1.85 mm (f) to 1.85 mm (f) ^b	85133C N4697E
5/16-inch, open-end torque wrench (set to 10 in-lbs)	8710-1765
1/4-inch, open-end wrench, thin profile	8710-0510

- a. This sensor and adapter must be calibrated together by the Agilent factory. The data supplied are only valid as long as the sensor and adapter remain connected.
- b. The 1.85 mm connector has the same ruggedness and is compatible with the 2.4 mm connector. 1.85 mm and 2.4 mm connectors and adapters may be used interchangeably.

Step 1. Verify the Model, Serial, and Option Numbers of the Analyzer

Refer to the License Key Certificate supplied with the kit:

- Verify that the analyzer’s model and serial numbers match those on the certificate.
- Verify that the option number on the certificate matches the option described by this installation note.

If the model, serial, or option number do not match the expected results, you will not be able to install the option. If this is the case, contact Agilent for assistance. Refer to [“Getting Assistance from Agilent”](#) on page 3.

Step 2. Remove the Outer and Inner Covers

Remove the Outer Cover

CAUTION This procedure is best performed with the analyzer resting on its front handles in the vertical position. *Do not place the analyzer on its front panel without the handles.* This will damage the front panel assemblies.

1. Disconnect the power cord (if it has not already been disconnected).
2. Using a T-20 TORX driver, remove the strap handles (item ①) by loosening the screws (item ②) on both ends until the handle is free of the analyzer.
3. Using a T-20 TORX driver, remove the four rear panel feet (item ③) by removing the center screws (item ④).
4. Slide the four bottom feet (item ⑤) off the cover.
5. Slide the cover off of the frame.

Figure 2 Outer Cover Removal

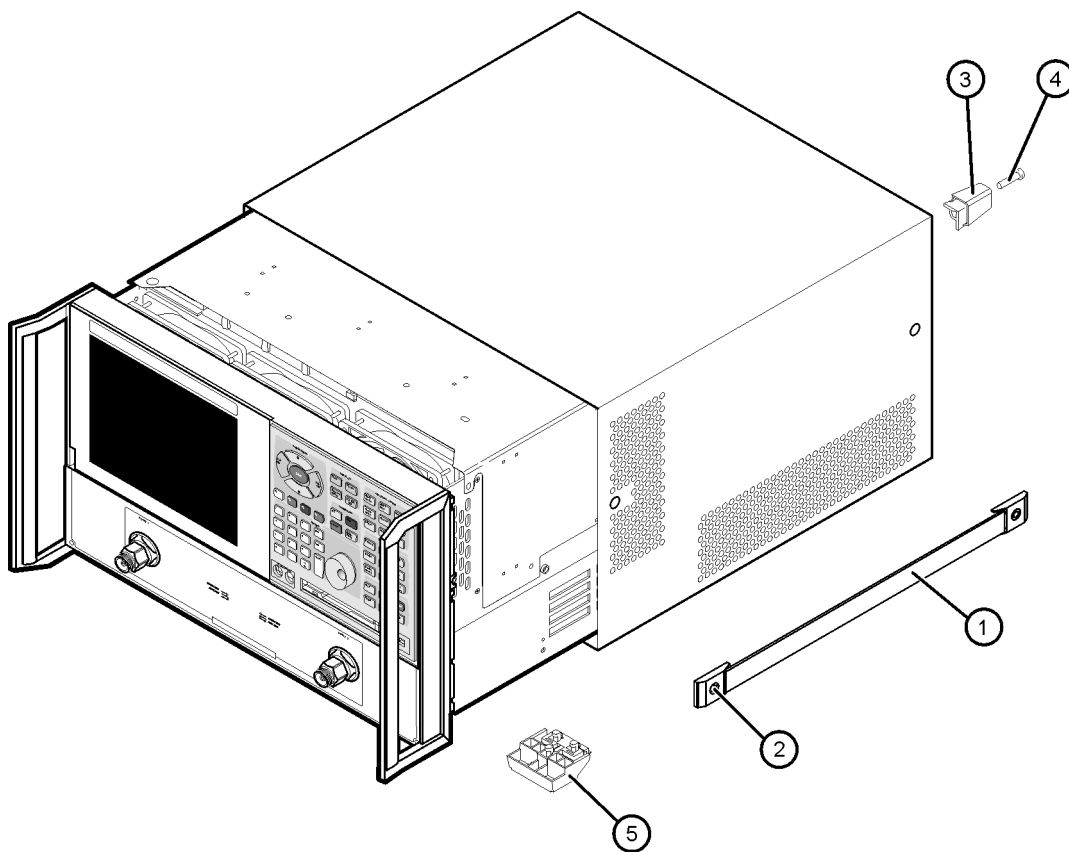

dt501a

Remove the Inner Cover

1. Place the analyzer top-side up on a flat surface.
2. Using a T-10 TORX driver, remove the eleven screws (item ①).
3. Lift off the cover.

Figure 3 Inner Cover Removal

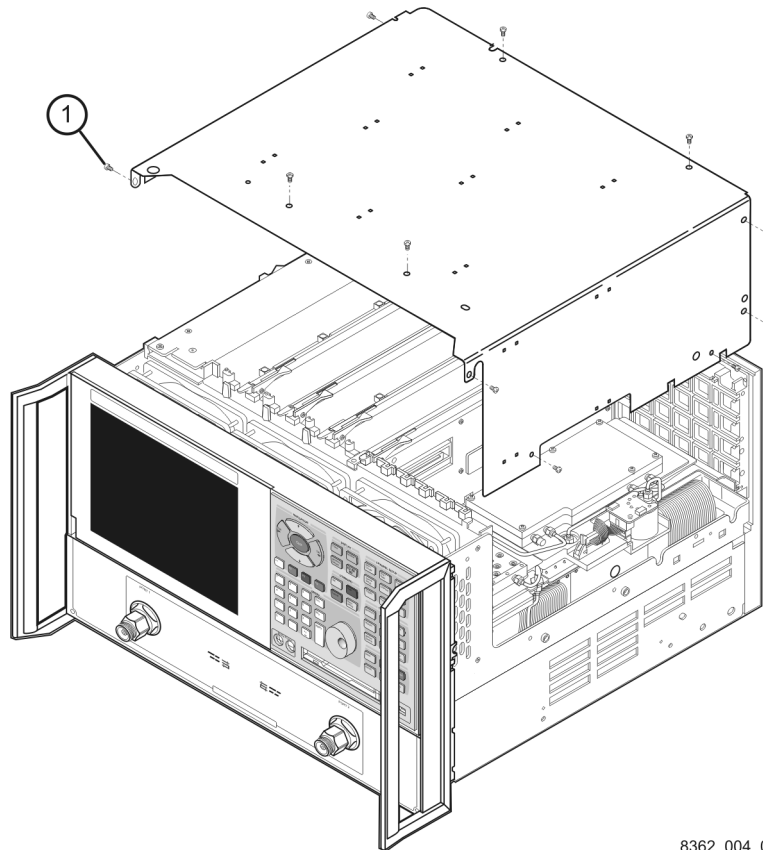

8362_004_01

Step 3. Replace the A12 Source 20

1. With a 5/16-inch wrench, disconnect semirigid cable (item ①).
2. Disengage the A12 source 20 from the A11 connector and slide it out of the analyzer while observing the **CAUTION** below.

CAUTION To avoid damage to the semirigid cable (item ①), pull down on the cable from the bottom side of the analyzer to move it away while sliding out the A12 source 20. The cable has some spring to it and the RF pin could be damaged by the A12 source 20.

Figure 4 A12 Source 20 Replacement

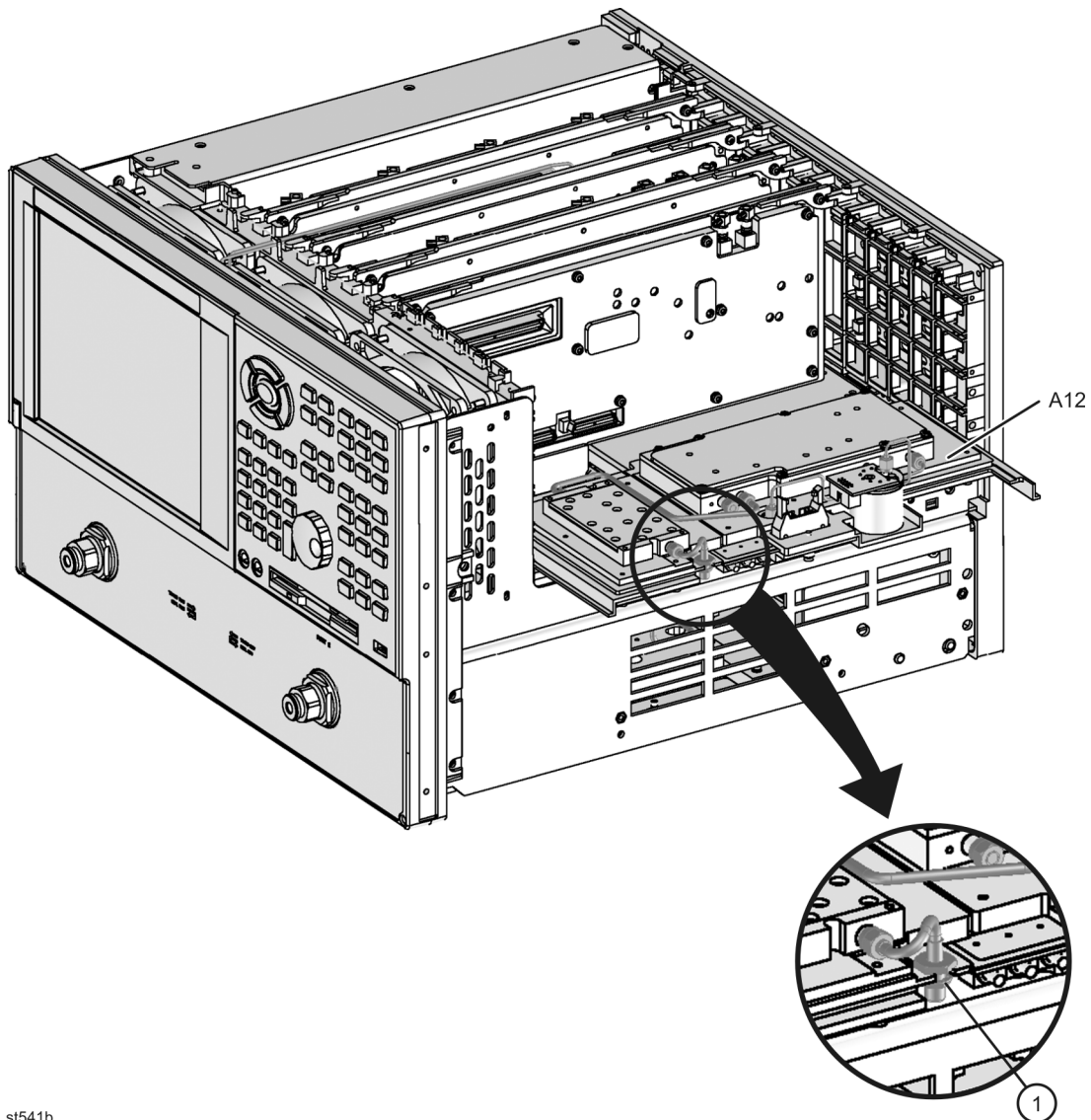

st541b

3. Slide the new A12 source 20 into the analyzer while observing the **CAUTION** above. Be sure that the assembly is seated completely into the A11 connector.
4. Reconnect the semirigid cable and tighten with a 5/16-inch torque wrench.

Step 4. Replace the Top Side to Bottom Side Cables

1. Place the analyzer on its side as shown.
2. Remove the cable hold-down wire (item ①).
3. Disconnect cables W19 and W20 at both ends; two top side connections and two bottom side connections.
4. Remove cables W19 and W20 from the analyzer.
5. Position the new cables provided into the analyzer. These cables are now designated as W20 and W21. Connect these cables to the top side connectors at A8J101 and A8J106 but do not connect the other ends to the A17 LOMA 10 as the LOMA 10 will be replaced.
6. Reinstall the cable hold-down wire (item ①).

Figure 5 Top Side to Bottom Side Cables Replacement

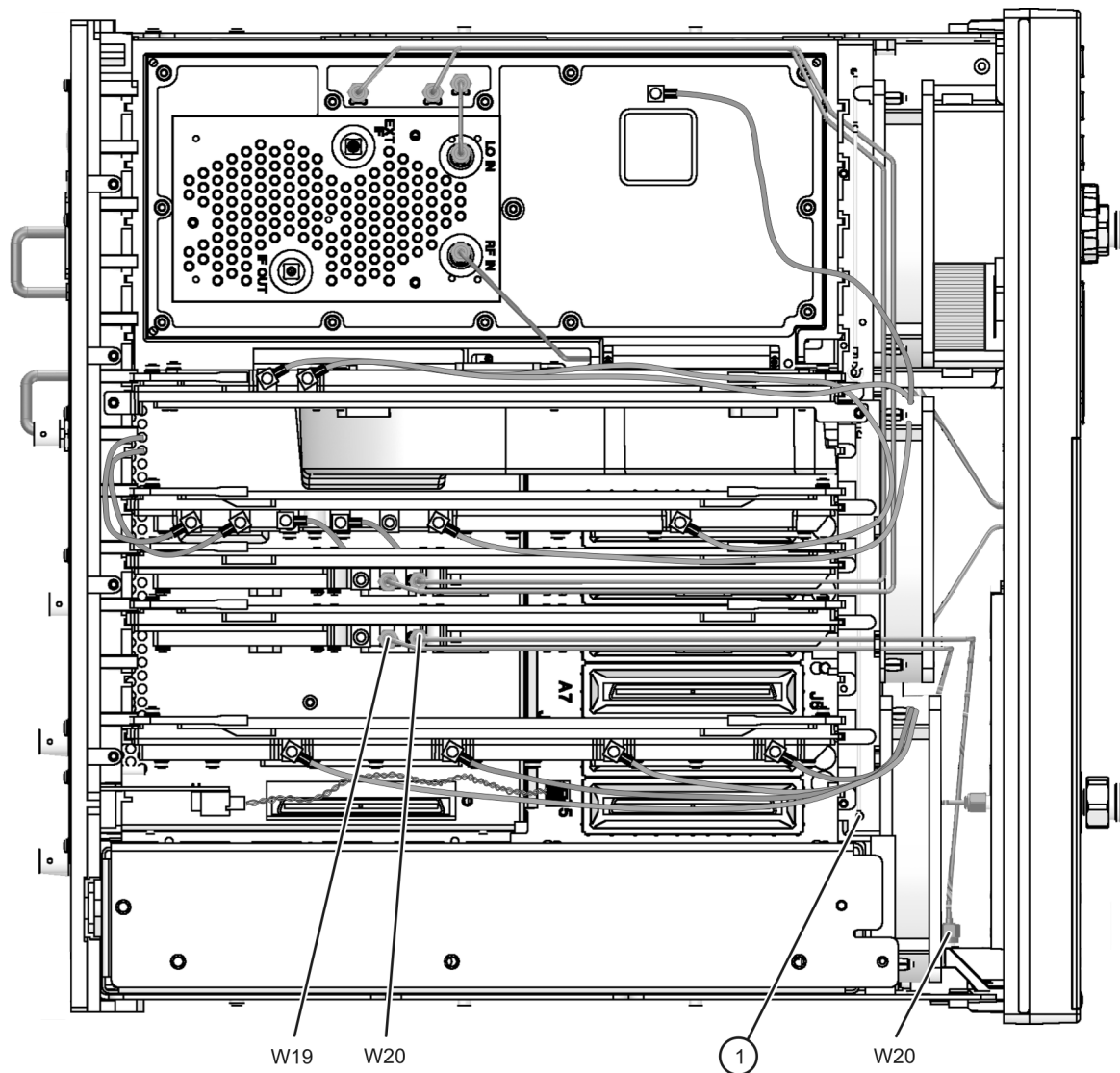

e8364_022_17

Step 5. Raise the Receiver Deck

1. Place the analyzer bottom-side up on a flat surface.
2. Using a T-10 TORX driver, remove the four screws, (item ①), that secure the receiver deck.
3. Pull the latch pin (item ②) towards the opposite side of the analyzer to release the receiver deck.
4. Lift the receiver deck to partially raise it, then release the latch pin (item ②). Lift the receiver deck to its fully raised position and ensure that the latch pin latches in the raised position.

Figure 6 Receiver Deck Raising

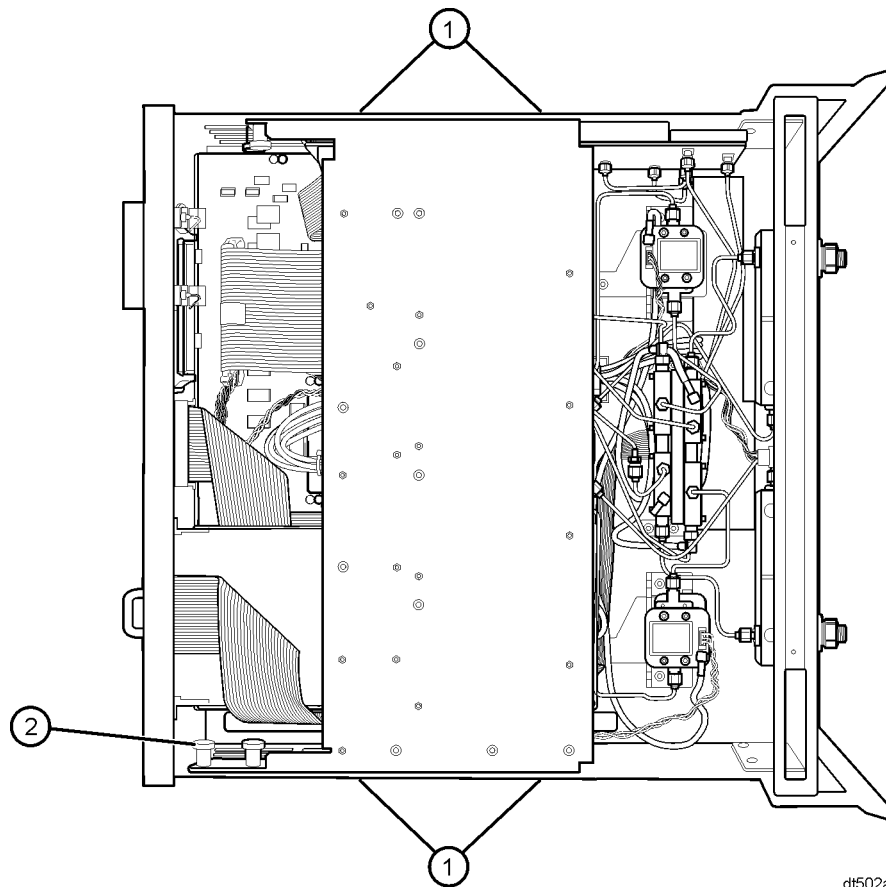

Step 6. Remove the Old Bottom Side Hardware and Cables

- Remove the A17 LOMA 10
- Remove the A18 MA 20
- Remove the A22 Switch/Splitter
- Remove the A23 and A24 Detectors
- Remove the A27, A28, A29, and A30 First Converters (Mixers)
- Remove the A25 and A26 Test Port Couplers

Remove the A17 LOMA 10

1. Using a 5/16-inch wrench, disconnect the three semirigid cables (item ①) from the A17 LOMA 10. Two of these cables should already be disconnected (from step 4).
2. Disconnect the ribbon cable (item ②) at the A17 LOMA 10.
3. Using a T-10 TORX driver, remove the four mounting screws (item ③) from the side of the analyzer. Retain the mounting screws for reinstallation later.

CAUTION Be careful not to damage the center pins of the semirigid cables. Some flexing of the cables is necessary to remove the assembly. Do not over-bend them.

4. Remove the A17 LOMA 10 from the analyzer. Observe the **CAUTION** above.

Figure 7 A17 LOMA 10 Removal

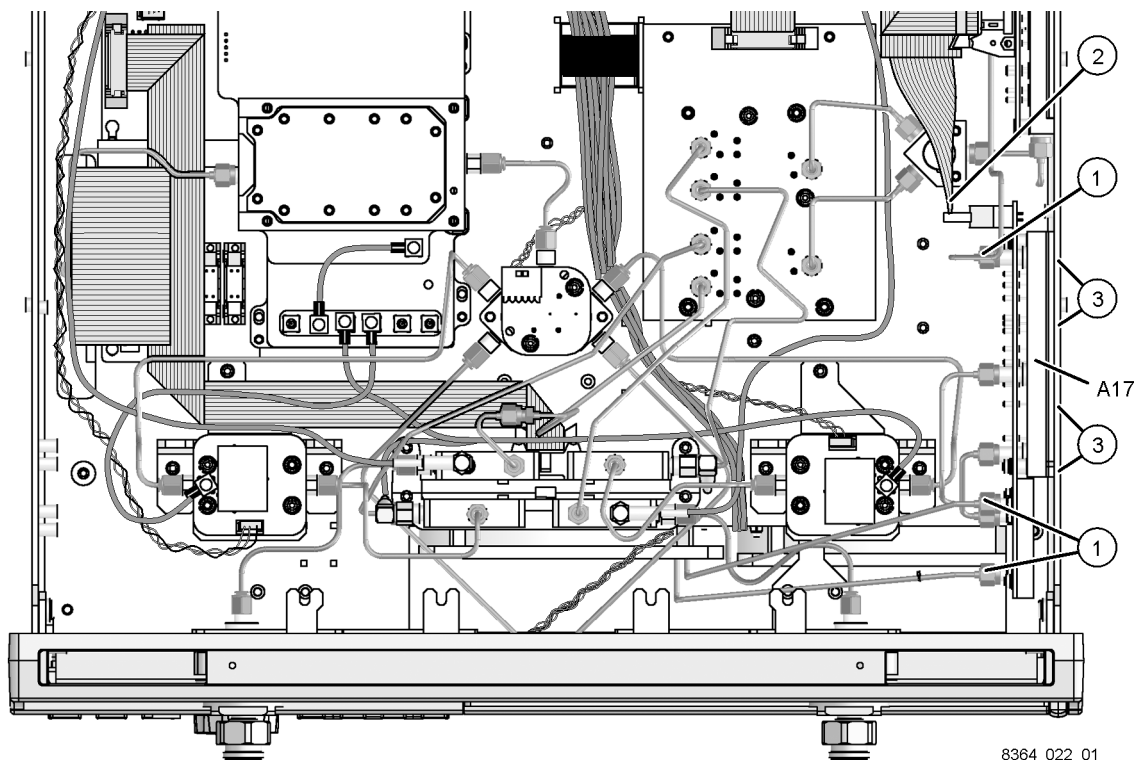

8364_022_01

Remove the A18 MA 20

1. Using a 5/16-inch wrench, disconnect the two semirigid cables (item ①) from the A18 MA 20. Remove these cables completely to allow the A18 MA 20 to be removed from the analyzer. Retain these cables for reinstallation later.
2. Disconnect the ribbon cable (item ②) at the A18 MA 20.
3. Using a T-10 TORX driver, remove the four mounting screws (item ③) from the side of the analyzer. Retain the mounting screws for reinstallation later.

CAUTION Be careful not to damage the center pins of the semirigid cables. Some flexing of the cables is necessary to remove the assembly. Do not over-bend them.

4. Remove the A18 MA 20 from the analyzer. Observe the **CAUTION** above.

Figure 8 A18 MA 20 Removal

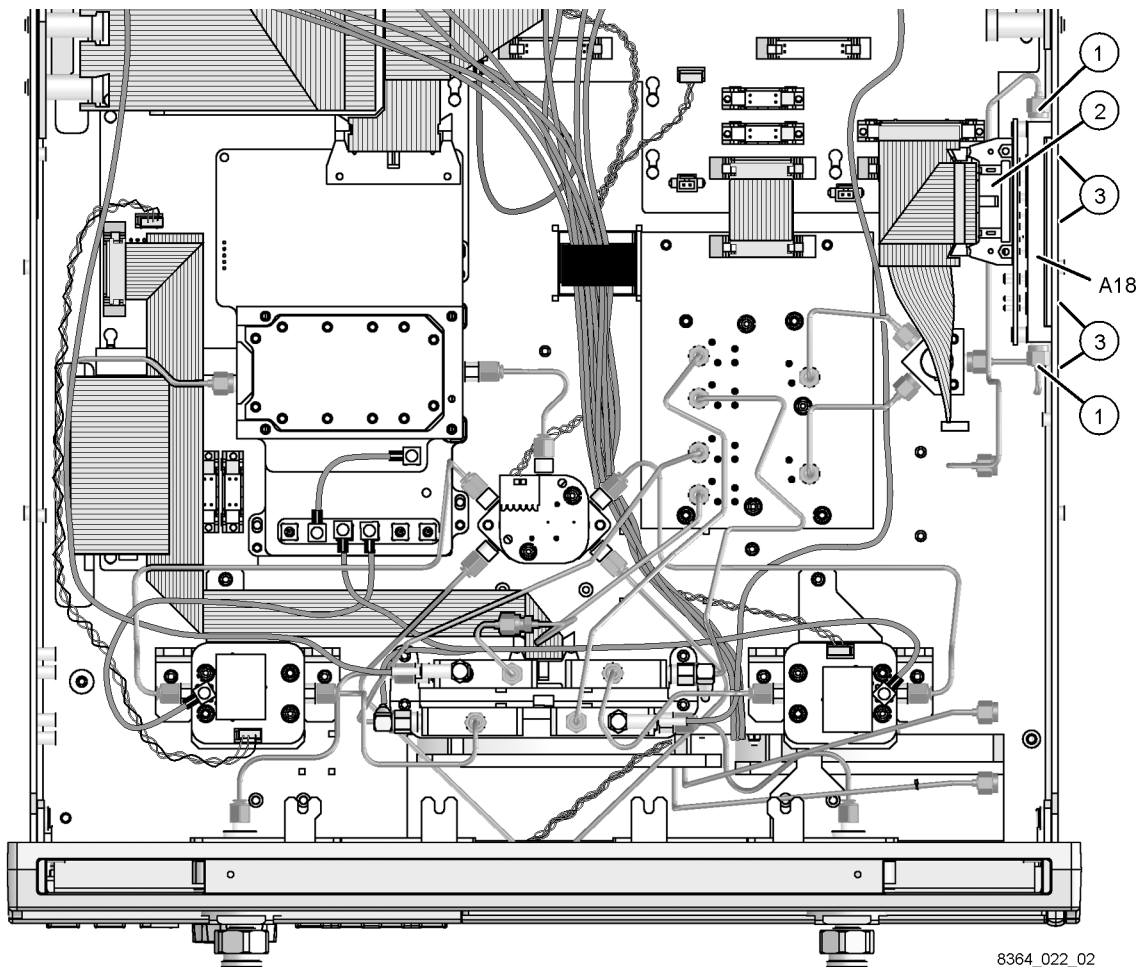

Remove the A22 Switch/Splitter

1. Disconnect the stranded switch control cable (item ①) from the A22 switch/splitter. Remove this cable completely from the analyzer and discard it. It will be replaced later.
2. Using a 5/16-inch wrench, remove the five semirigid cables (item ②). Discard these cables, they will be replaced with new ones.
3. Using a T-10 TORX driver, remove the two mounting screws (item ③). Retain the mounting screws for reinstallation later.

CAUTION Be careful not to damage the center pins of the semirigid cables. Some flexing of the cables is necessary to remove the assembly. Do not over-bend them.

4. Remove the A22 switch/splitter from the analyzer. Observe the **CAUTION** above. Discard this switch/splitter, it will be replaced with a new one.

Figure 9 A22 Switch/Splitter Removal

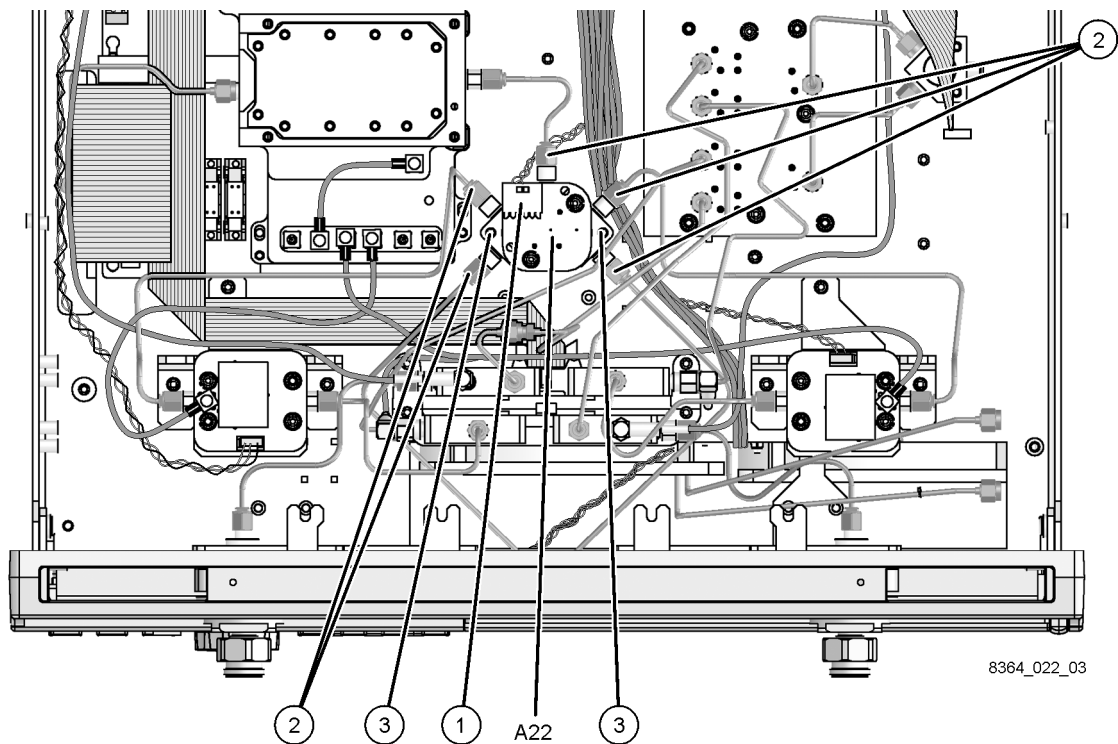

Remove the A23 and A24 Detectors

1. Disconnect the stranded control cable (item ①) from each detector. Remove and discard this cable, it will not be used.
2. Using a 5/16-inch wrench, disconnect the remaining semirigid cable (item ②) from each detector. Remove and discard these cables, they will not be used.
3. Remove the flexible cable (item ③) from each detector and discard them, they will not be used.
4. Using a T-10 TORX driver, remove the three mounting screws (item ④) from each bracket to which the detectors are attached.
5. Remove the brackets, with the detectors attached, from the analyzer and discard them, they will not be used.

Figure 10 A23 and A24 Detectors Removal

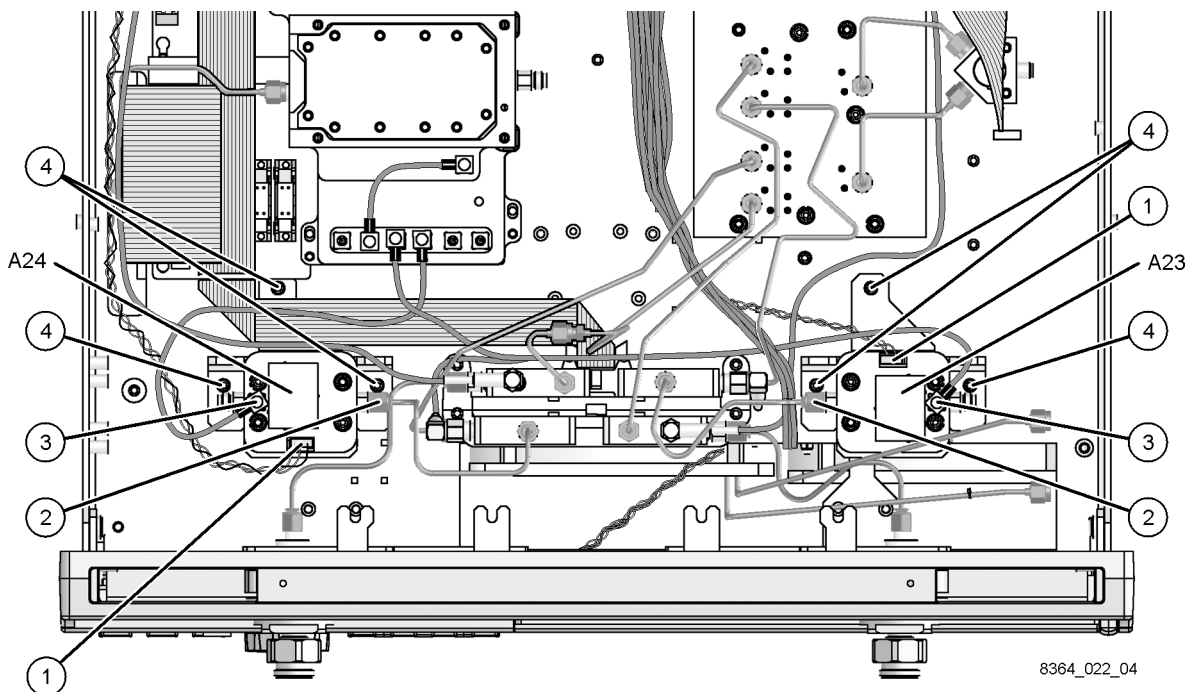

Remove the A27, A28, A29, and A30 First Converters (Mixers)

1. Using a 5/16-inch wrench, disconnect the six semirigid cables (item ①) and the four flexible cables (item ②).
2. Using a T-10 TORX driver, remove the four mounting screws (item ③). Retain the mounting screws for reinstallation later.

CAUTION Be careful not to damage the center pins of the semirigid cables. Some flexing of the cables is necessary to remove the assembly. Do not over-bend them.

3. Remove the mixer bracket with all four mixers attached and disconnect the ribbon cable (item ④). Observe the **CAUTION** above. Set this item aside for modification later.

Figure 11 A27, A28, A29, and A30 First Converters Removal

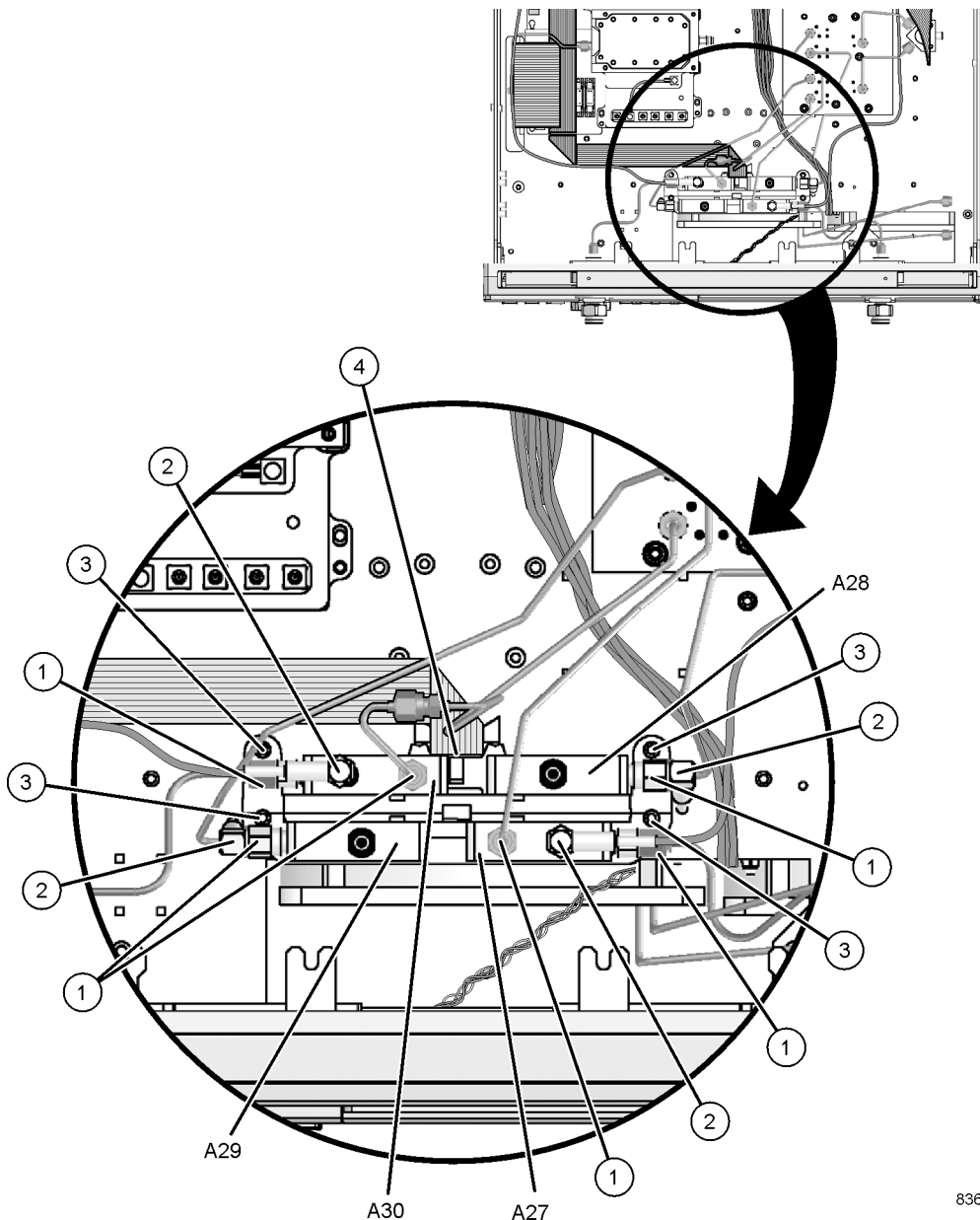

8364_022_05

Remove the A25 and A26 Test Port Couplers

1. Using a 5/16-inch wrench, remove the two semirigid cables (item ①) from each of the test port couplers. Discard these cables, they will be replaced with new ones.
2. Using a 1-inch wrench, remove the test port coupler nuts (item ②) from the front panel. Retain the test port coupler nuts for reinstallation later.

CAUTION Be careful not to damage the center pins of the semirigid cables. Some flexing of the cables is necessary to remove the assembly. Do not over-bend them.

3. Remove the A25 and A26 test port couplers from the analyzer. Observe the **CAUTION** above.

Figure 12 A25 and A26 Test Port Couplers Removal

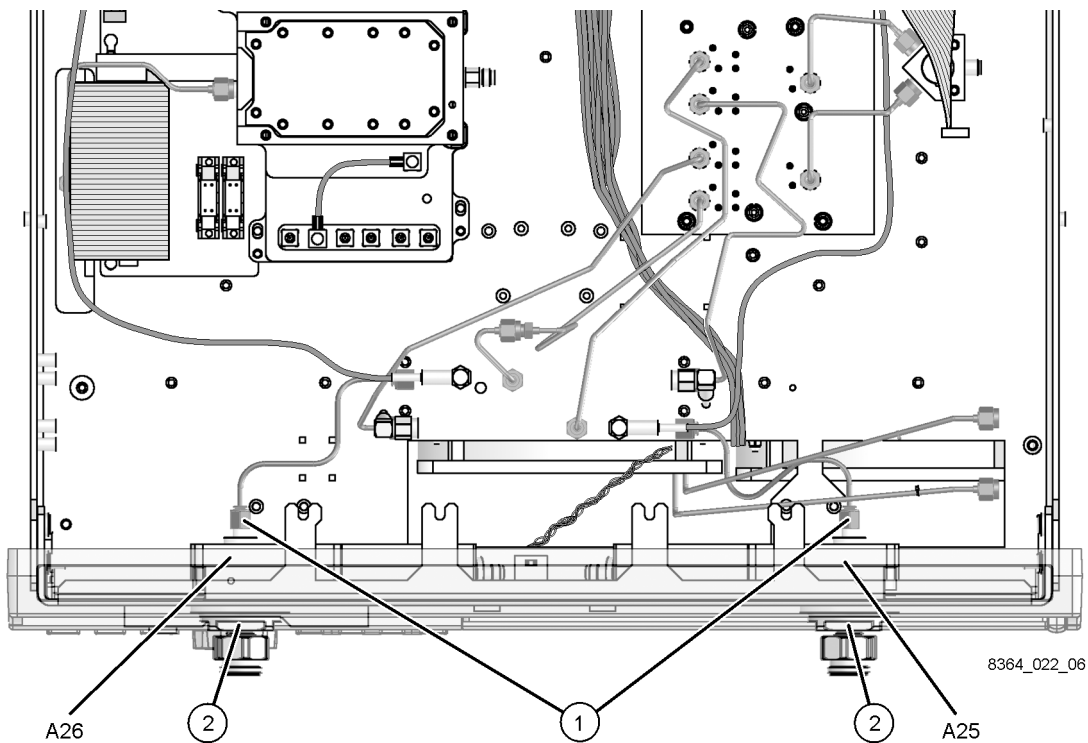

Step 7. Install the New Hardware and Cables

- Install the New A17 LOMA 12
- Install the New A18 MA 24
- Install the New A25 and A26 Test Port Couplers
- Install the New A23 and A24 SOMA 70s
- Install the New A22 Switch
- Install the New A27, A28, A29, and A30 First Converters (Mixers)
- Install the New Cables

Install the New A17 LOMA 12

1. Position the new A17 LOMA 12 in the analyzer as shown. Observe the **CAUTION** below.

CAUTION Be careful not to damage the center pins of the semirigid cables. Some flexing of the cables is necessary when installing the assembly. Do not over-bend them.

2. Using a T-10 TORX driver, install three of the four mounting screws (item ③), previously removed from the old A17 LOMA 10, through the side of the analyzer as shown. One of the screws removed previously is not reused.
3. Using a 5/16-inch torque wrench (set to 10 in-lbs), reconnect the two semirigid cables (item ①) to the A17 LOMA 12. Observe the **CAUTION** above.
4. Reconnect the ribbon cable (item ②) to the A17 LOMA 12.

Figure 13 A17 LOMA 12 Installation

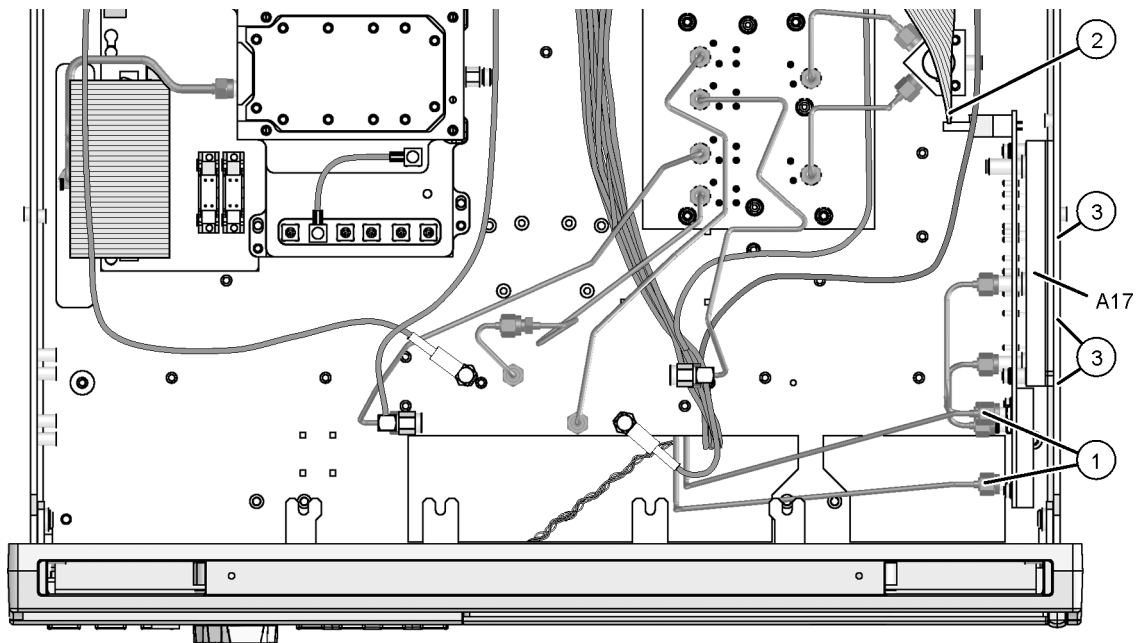

8364_022_07

Install the New A18 MA 24

1. Position the new A18 MA 24 in the analyzer as shown. Observe the **CAUTION** below.

CAUTION Be careful not to damage the center pins of the semirigid cables. Some flexing of the cables is necessary when installing the assembly. Do not over-bend them.

2. Using a T-10 TORX driver, install the four mounting screws (item ③), previously removed from the old A18 MA 20, through the side of the analyzer.
3. Using a 5/16-inch torque wrench (set to 10 in-lbs), reconnect the two semirigid cables (item ①) to the A18 MA 24. Observe the **CAUTION** above.
4. Reconnect the ribbon cable (item ②) to the A18 MA 24.

Figure 14 A18 MA 24 Installation

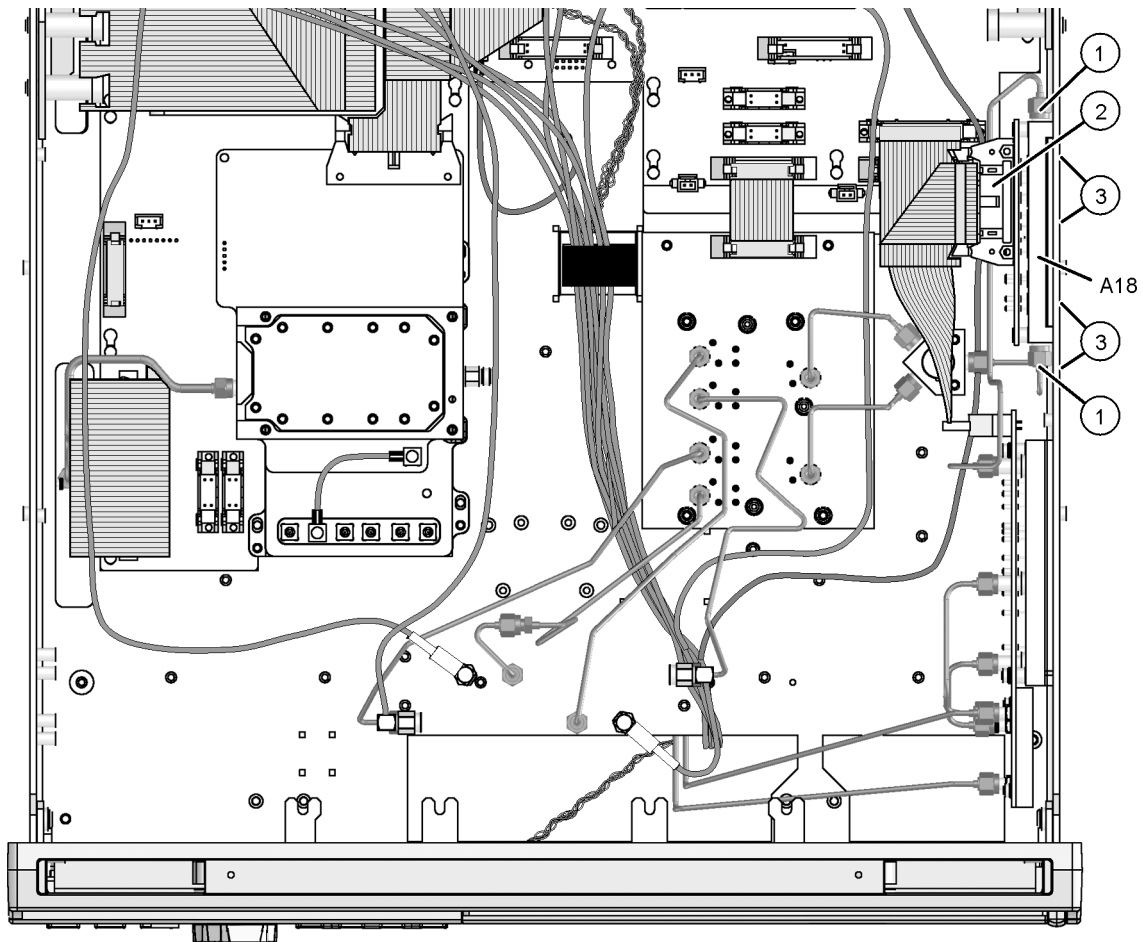

8364_022_08

Install the New A25 and A26 Test Port Couplers

1. Position the A25 and A26 test port couplers in the analyzer as shown.
2. Install the test port coupler nuts (item ①) and, with a 1-inch torque wrench, tighten them to 72 in-lbs.
3. The cables will be installed later.

Figure 15 A25 and A26 Test Port Couplers Installation

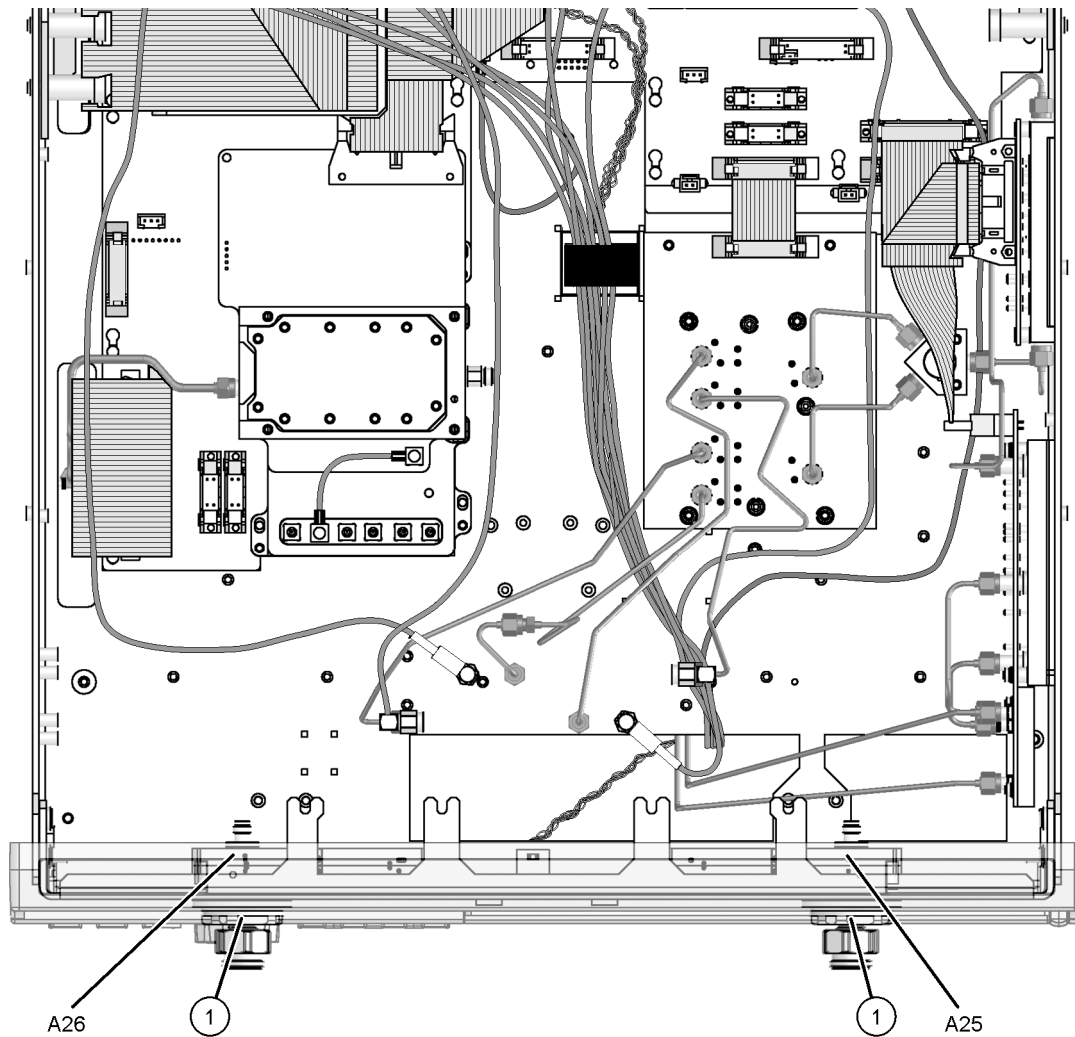

8364_022_09

Install the New A23 and A24 SOMA 70s

1. Place the SOMA 70 mounting brackets (item ①) in the analyzer as shown.
2. Using a T-10 TORX driver, install three mounting screws (item ②) in each bracket.

Figure 16 SOMA 70 Brackets Installation

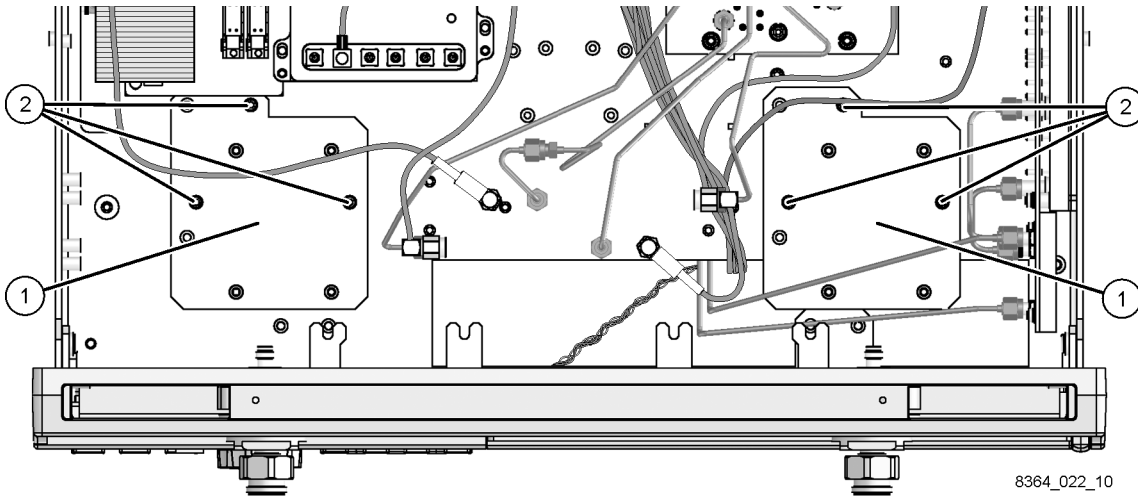

3. Position the A23 and A24 SOMA 70s on the brackets as shown.
4. Using a T-10 TORX driver, install four mounting screws (item ③) in each SOMA 70.
5. The cables will be installed later.

Figure 17 A23 and A24 SOMA 70s Installation

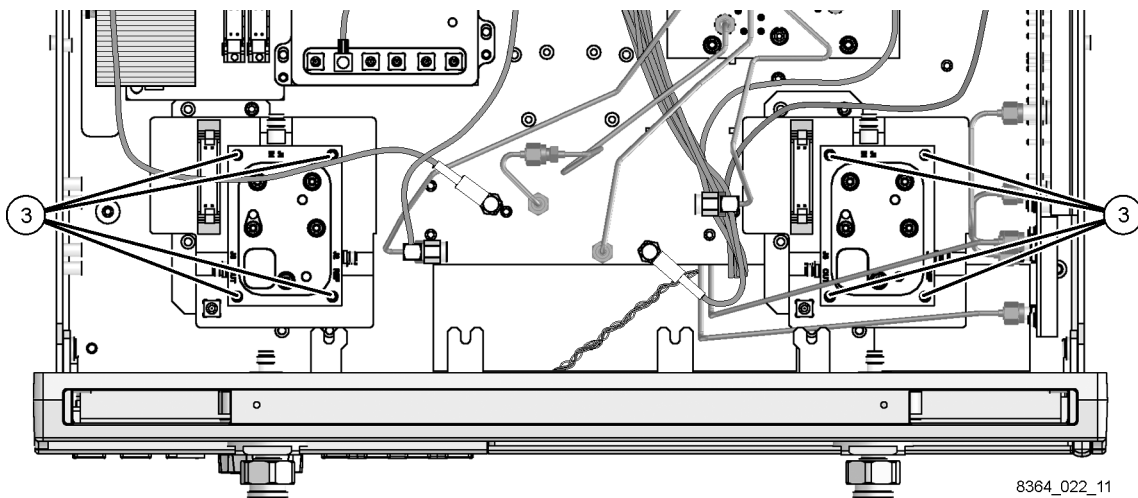

Install the New A22 Switch

1. Position the A22 switch in the analyzer as shown.
2. Using a T-10 TORX driver, install the four mounting screws (item ①). Two screws were retained from removal of the A22 switch/splitter and an additional two are provided.
3. The cables will be installed later.

Figure 18 A22 Switch Installation

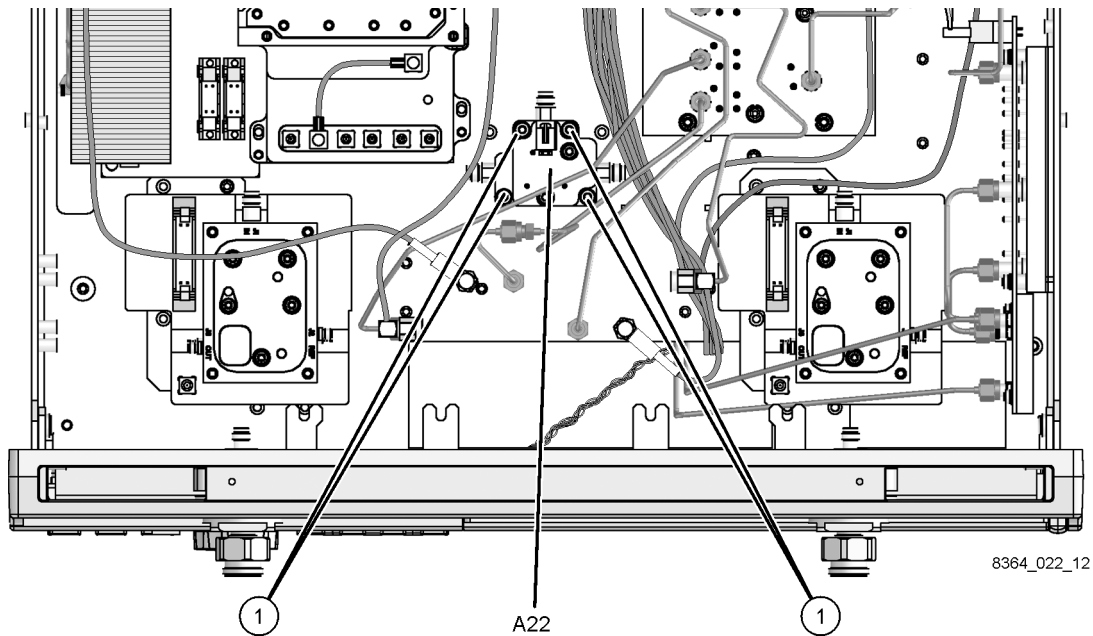

Install the New A27, A28, A29, and A30 First Converters (Mixers)

1. Remove all four mixers from the previously removed mixer bracket by removing three screws (item ①) from each mixer. Retain the screws.
2. Remove the mixer bias board by removing the four attachment screws (item ②). Retain the screws.
3. Install the new mixer bias board onto the bracket by *loosely* installing the attachment screws (item ②) from the old mixer bias board. Do not tighten the screws at this time.
4. Using a T-10 TORX driver, install the four new mixers onto the bracket using the screws (item ①) from the previously removed mixers. Be sure to orient the mixers as shown, and be sure that the DC feed-through pins align properly with the mixer bias board.
5. Using a T-10 TORX driver, tighten the mixer bias board attachment screws (item ②).
6. The mixer bracket with new mixers attached is now ready to be installed in the analyzer.

Figure 19 Mixers Bracket Assembly

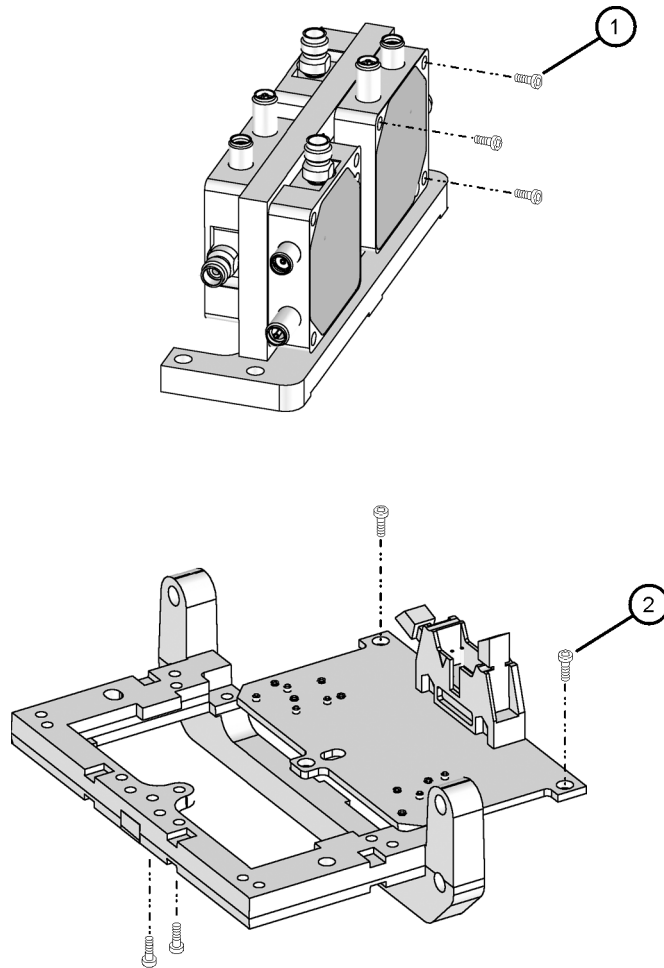

8364_022_13

7. Connect the ribbon cable (item ④) and place the mixer bracket, with all four mixers attached, into the analyzer. Observe the **CAUTION** below.

CAUTION Be careful not to damage the center pins of the semirigid cables. Some flexing of the cables is necessary when installing the assembly. Do not over-bend them.

8. Using a T-10 TORX driver, install the four mounting screws (item ③).
9. Using a 5/16-inch torque wrench (set to 10 in-lbs), reconnect the four semirigid cables (item ①) and the four flexible cables (item ②) shown. Observe the **CAUTION** above. The remaining cables will be installed later.

Figure 20 A27, A28, A29, and A30 Mixers Installation

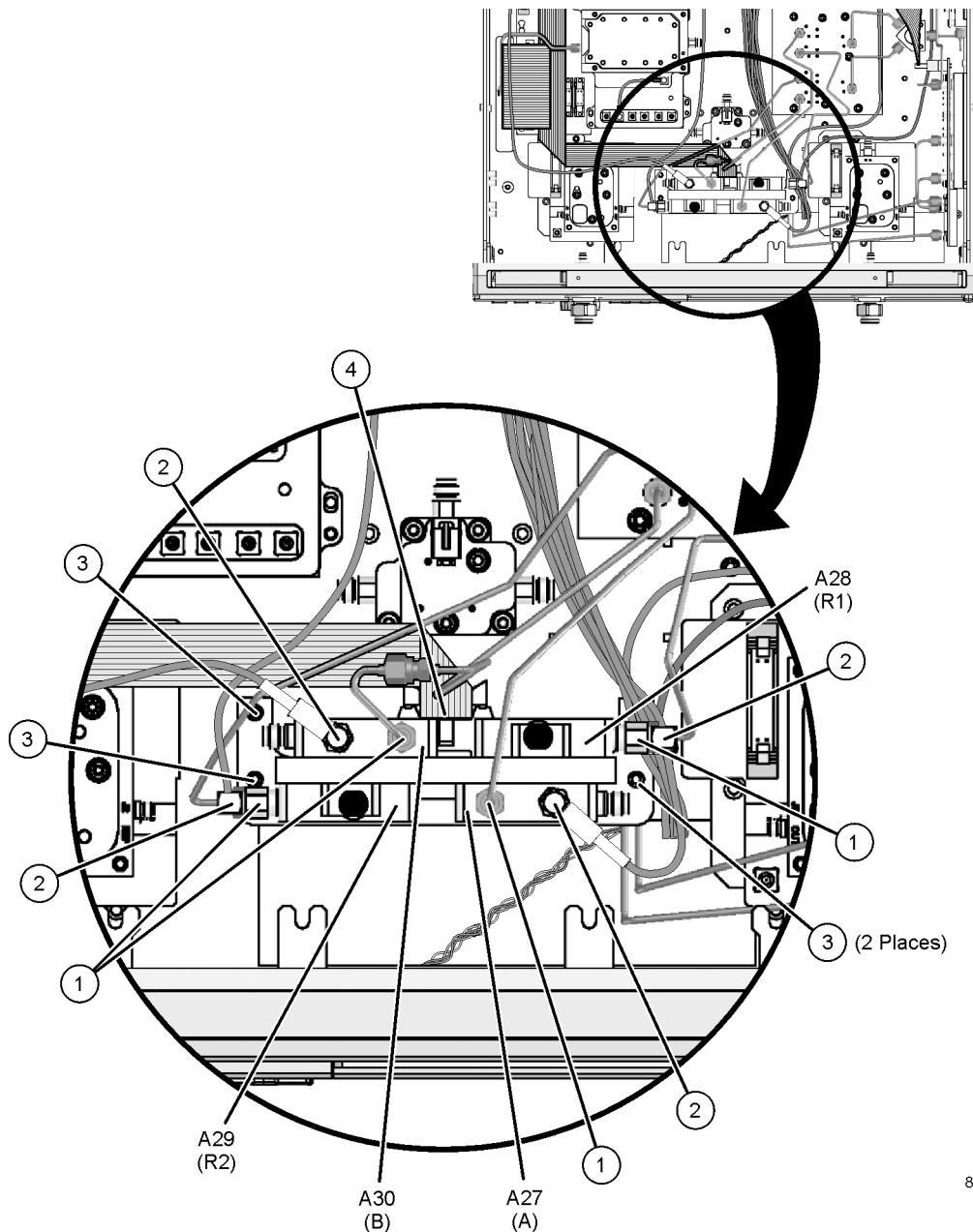

8364_022_14

Install the New Cables

CAUTION Be very careful with these cables with 1.85 mm connectors. They are extremely delicate and can be easily damaged.

Using a 5/16-inch torque wrench set to 10 in-lbs, install the following new cables **in the order listed**. These new parts are listed in [Table 1 on page 5](#).

- W2 A21 SOMA 50 to A22 switch
- W3 A22 switch to A23 SOMA 70
- W4 A22 switch to A24 SOMA 70
- W8 A24 SOMA 70 to A29 channel R2 mixer
- W6 A24 SOMA 70 to A26 test port 2 coupler
- W10 A26 test port 2 coupler to A30 channel B mixer
- W7 A23 SOMA 70 to A28 channel R1 mixer
- W5 A23 SOMA 70 to A25 test port 1 coupler
- W9 A25 test port coupler 1 to A27 channel A mixer
- W38 A23 SOMA 70 to A16 test set motherboard J204 (R1)
- W39 A24 SOMA 70 to A16 test set motherboard J205 (R2)
- ① Wrapped wire cable; A22 switch to A16 test set motherboard J500. Route this cable under the cable clamp as shown.
- ② Ribbon cable; A24 SOMA 70 to A16 test set motherboard J40 (SOMA70_2). Shape and route this cable as shown.
- ③ Ribbon cable; A23 SOMA 70 to A16 test set motherboard J50 (SOMA70_1). Shape and route this cable as shown.

Figure 21 New Cables Installation

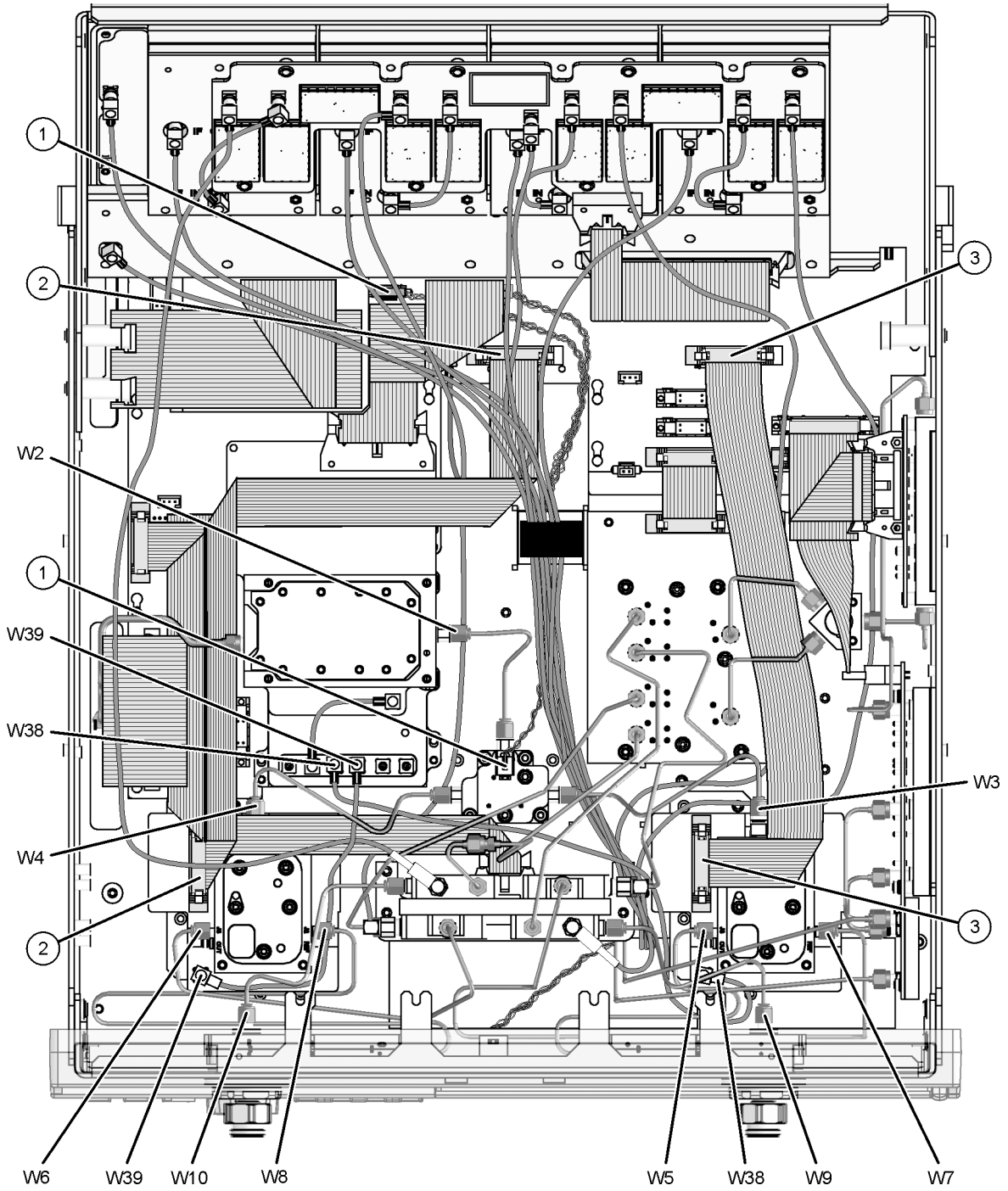

8364_022_15

Step 8. Lower the Receiver Deck

1. Pull the latch pin (item ②) towards the opposite side of the analyzer to release the receiver deck.
2. Lift the receiver deck to partially lower it, then release the latch pin (item ②). Lower the receiver deck to its fully lowered position and ensure that the latch pin latches in the lowered position.
3. Using a T-10 TORX driver, reinstall the four screws, (item ①), to secure the receiver deck.

Figure 22 Receiver Deck Lowering

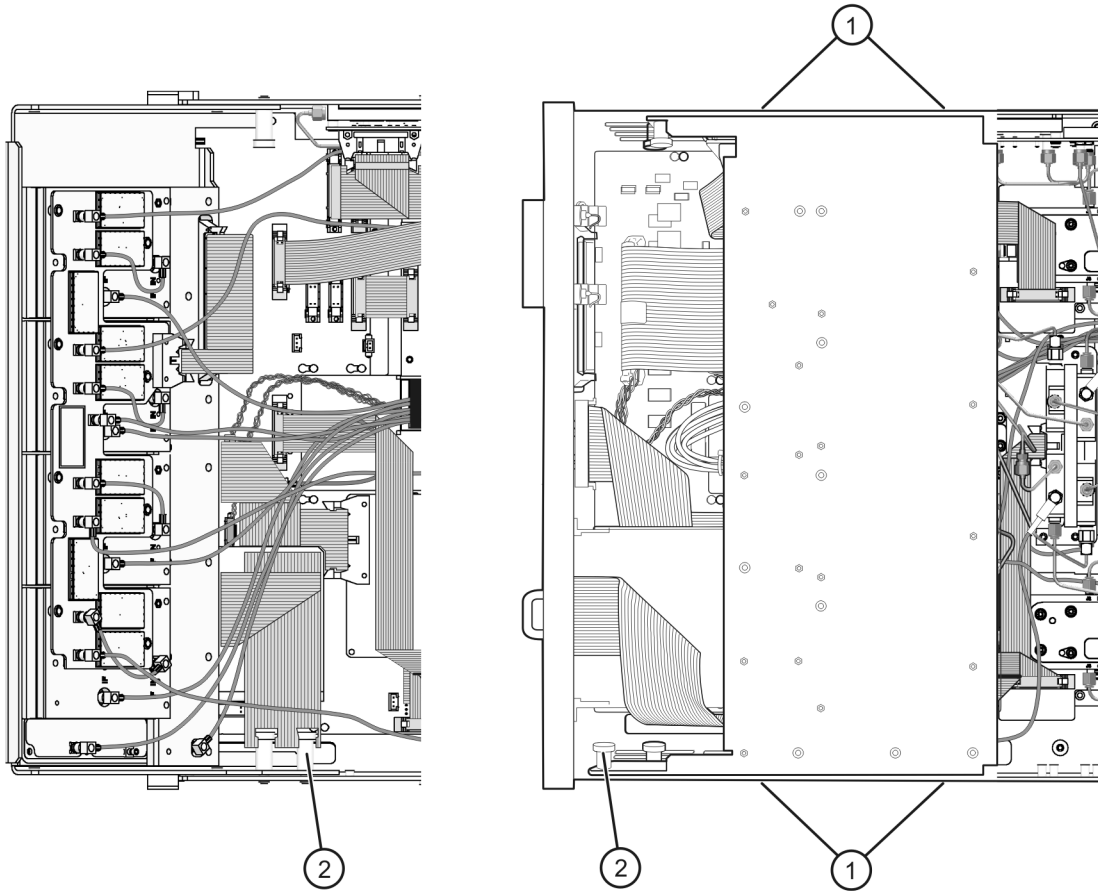

8364_022_16

Step 9. Replace the Front Panel Nameplate and Overlay

Remove the Old Nameplate

1. Using a sharp object such as a knife blade, lift one end of the old nameplate (item ①). Be careful not to scratch the painted surface.
2. Using your fingers, pull the nameplate completely off of the front panel and discard it.
3. If any adhesive remains on the front panel surface, it can be removed by rubbing it with your finger. Do not use a sharp object to remove this adhesive. If necessary, the surface can be cleaned with isopropyl alcohol.

Install the New Nameplate

1. Remove the protective backing from the new nameplate to expose the adhesive. Avoid touching the adhesive with your fingers as this may affect its ability to adhere to the front panel surface.
2. *Loosely* align the new nameplate over the recess in the front panel and apply lightly.
3. Once the nameplate is properly aligned, press it firmly onto the surface to secure it.

Figure 23 Model Number Nameplate Replacement

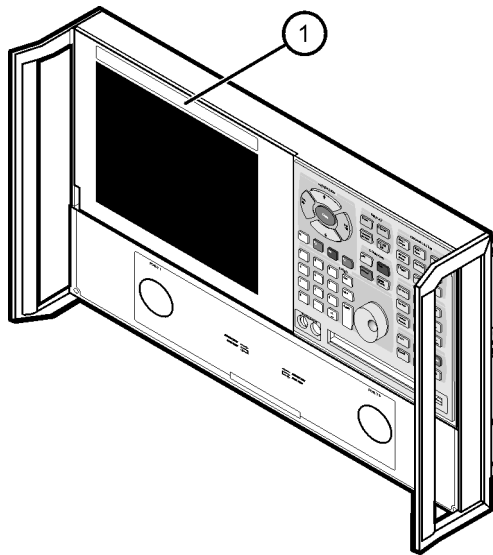

8363_001_01

Remove the Old Overlay

1. From the back side of the front panel, use a blunt object in one of the cutouts in the lower frame to push the overlay (item ①) and separate it from the front panel.
2. From the front side of the front panel, pull the overlay completely off and discard it.
3. If any adhesive remains on the front panel surface, it can be removed by rubbing it with your finger. Do not use a sharp object to remove this adhesive. If necessary, the surface can be cleaned with isopropyl alcohol.

Install the New Overlay

1. Remove the protective backing from the new front panel overlay to expose the adhesive.
2. Starting from either the left or right side, *loosely* place the overlay in the recess on the lower front panel, ensuring that it fits tightly against the recess edges.
3. Once the overlay is properly aligned, press it firmly onto the surface to secure it.

Figure 24 Front Panel Overlay Replacement

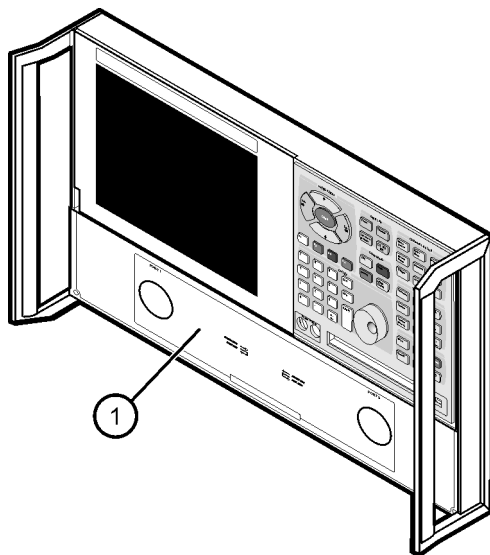

dt519a

Step 10. Reinstall the Inner and Outer Covers

Reinstall the Inner Cover

1. Place the analyzer top-side up on a flat surface.
2. Place the cover in position on the analyzer.
3. Using a T-10 TORX driver, install the eleven screws (item ①).

Figure 25 Inner Cover Reinstallation

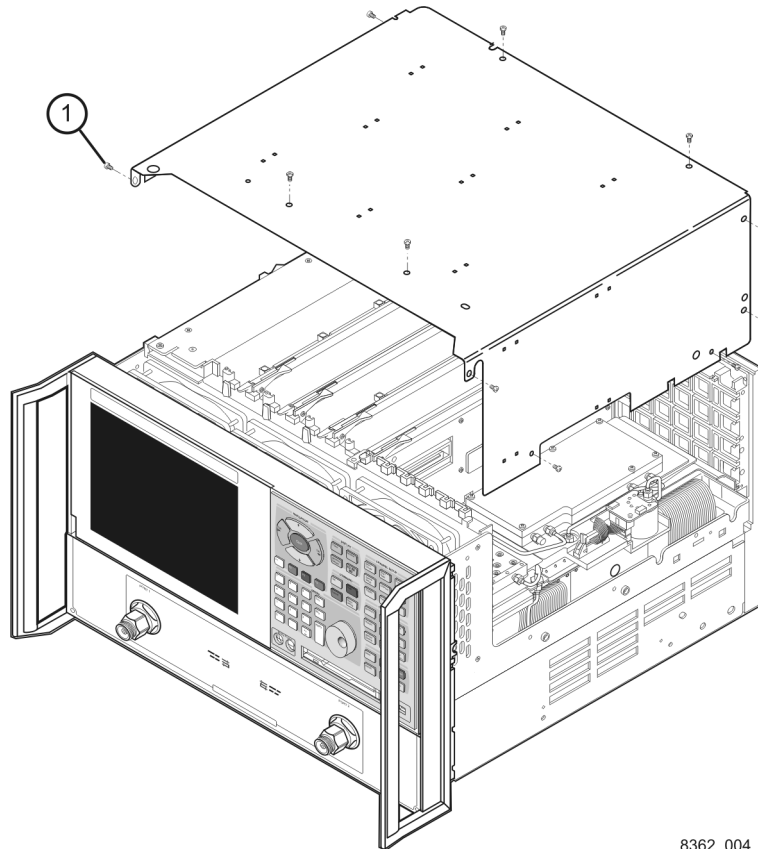

8362_004_01

Reinstall the Outer Cover

CAUTION

This procedure is best performed with the analyzer resting on its front handles in the vertical position. *Do not place the analyzer on its front panel without the handles.* This will damage the front panel assemblies.

1. Slide the cover onto the frame.
2. Using a T-20 TORX driver, install the four rear panel feet (item ③) by installing the center screws (item ④).
3. Slide the four bottom feet (item ⑤) onto the cover.
4. Using a T-20 TORX driver, install the strap handles (item ①) by tightening the screws (item ②) on both ends.

Figure 26 Outer Cover Reinstallation

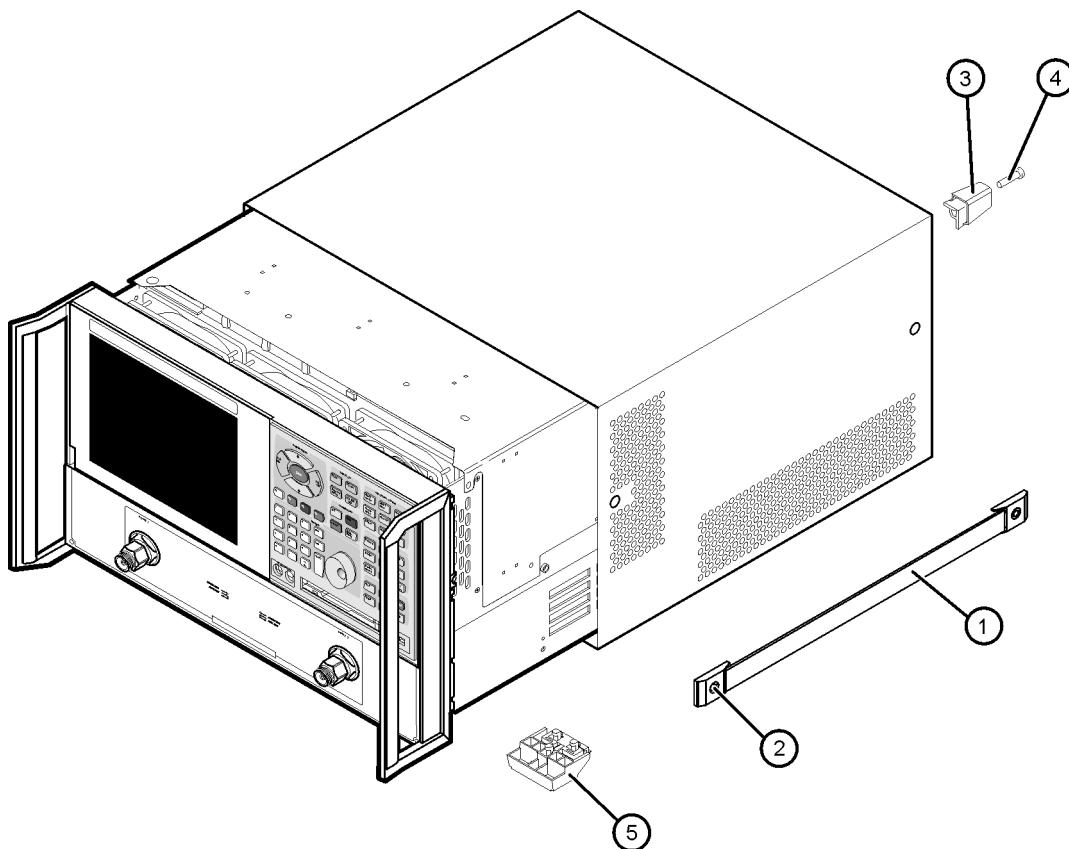

dt501a

Step 11. Enter the New Model Number

Procedure Requirements

- The analyzer must be powered up and operating to perform this procedure.
- The Network Analyzer program must be running.
- A keyboard and a mouse must be connected to the analyzer for this procedure.

Enter the New Model Number

1. On the analyzer's **System** menu, point to **Service**, then click **Option Enable**.
2. Click **Repair**.
3. Check **Model shown is incorrect!**, then click **Begin Repair**.
4. In the **Model Change** box, select the new model number, **E8361A**.
5. Using the keyboard, enter the keyword in the box provided. The keyword is printed on the License Key Certificate. Enter this keyword *exactly* as it is printed on the certificate.
6. Click **Enter Model**.
7. Verify that the new model number displayed is correct, then click **YES**. If it is not correct, click **NO** and repeat the repair.
8. When the installation is complete, click **Exit**.

Verify that the New Model Number is Shown Correctly

1. On the analyzer's **Help** menu, click **About Network Analyzer**.
2. Verify that the new model number, E8361A, is shown correctly in the display.
3. Click OK.
4. On the analyzer front panel, press **Preset**. Verify that the full frequency range of the analyzer is correct. The analyzer should preset to a frequency range of 10 MHz to 67 GHz.

Step 12. Perform Post-Upgrade Adjustments

The following adjustments must be made due to the hardware changes made to the analyzer. **Perform these adjustments in the order listed.**

- 3.8 GHz PMYO frequency
- LO power
- offset LO
- source calibration
- phase lock IF gain
- receiver calibration

These adjustments are described in the PNA service guide and in the PNA on-line HELP. A list of equipment required to perform these adjustments can be found at [“Test Equipment Required for Post-Upgrade Adjustments” on page 9.](#)

Performance Tests and System Verification

The analyzer should now operate and phase lock over its entire frequency range.

If you experience difficulty with the basic functioning of the analyzer, contact Agilent. Refer to [“Getting Assistance from Agilent” on page 3.](#)

Although the analyzer functions, its performance relative to its specifications has not been verified for the additional frequency range enabled by this upgrade.

It is recommended that a full instrument calibration be performed using the N2721A performance test software.

If the testing of the analyzer’s full range of specifications is not required, a system verification can be performed.

Refer to the analyzer’s service guide for information on performance tests and system verification.